



DESIGN NOTES

3MHz Micropower Synchronous Boost Converters Deliver 3W from Two Cells in a Tiny MSOP Package – Design Note 246

Mark Jordan

Portable electronic devices operating from one or more alkaline or nickel-metal-hydride cells require a boosted supply that is both small and efficient. Linear Technology's new LTC[®]3401 and LTC3402 are high frequency micropower synchronous boost converters that operate from an input voltage below 1V and deliver up to 1A of output current from two cells. DC/DC efficiency can be as high as 97%. The operating frequency, output voltage and Burst Mode™ operation are all user programmable, allowing these products to fit in various applications where size considerations must be balanced against efficiency. Furthermore, all of this functionality is packed into a small, thermally enhanced MSOP-10 package.

The LTC3401 is optimized for applications requiring less than 1.5W of total output power from two alkaline cells, whereas the LTC3402 is optimized for applications requiring 3W or less from two cells. High efficiency is achieved through internal features such as lossless current sensing, low gate charge, low $R_{DS(ON)}$ synchronous power switches (0.16Ω NMOS, 0.18Ω PMOS) and fast switching transitions to minimize power loss. An external Schottky diode is not required, but may be used to maximize efficiency.

The current mode control architecture, along with OPTI-LOOP™ compensation and adaptive slope compensation, allows the transient response to be optimized over a wide range of loads, input voltages and output capacitors. The IC remains in fixed-frequency mode until the user forces the IC to enter Burst Mode operation by driving the MODE/SYNC pin high. The IC consumes only 38μA of quiescent current in Burst Mode operation, maximizing efficiency at light loads. The part can also be commanded to shut down by pulling the SHDN pin low when the part draws less than 1μA of quiescent current. The PGOOD pin provides an open-drain output flag that pulls low when the output voltage is more than 9% below the regulation voltage.

All-Ceramic-Capacitor, 2-Cell to 3.3V, 1A Converter

A 3W, 2-cell alkaline application using the LTC3402 is shown in Figure 1. The operating frequency is set at 1MHz for this application, providing a good compromise between size and efficiency. The area of the converter is less than 0.25in². The efficiency of the circuit of Figure 1 is shown in Figure 2. The efficiency peaks at 96% at 300mW output power and is greater than 85% up to 3W. The Burst Mode efficiency is 80% with a 500μA load, making it ideal for applications that power down for extended periods of time.

In many applications, the output filter capacitance can be reduced for the desired transient response by having the device commanding the change in load current (i.e., system microcontroller) inform the power converter of the changes as they occur. Specifically, a “load-feedforward” signal coupled into the V_C pin gives the inner current loop a head start in providing the change in output current. The transconductance of the LTC3402 converter

LT, LTC and LT are registered trademarks of Linear Technology Corporation. Burst Mode and OPTI-LOOP are trademarks of Linear Technology Corporation.

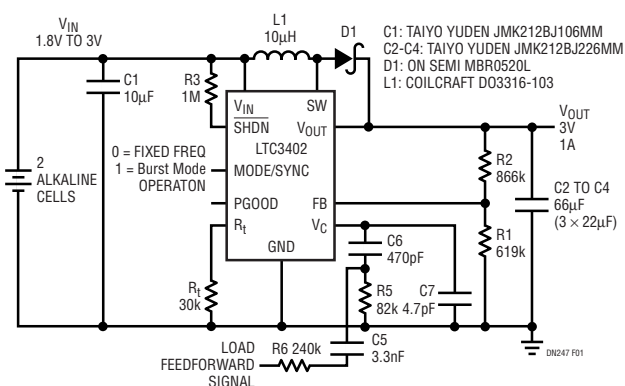

Figure 1. 2-Cell to 3V at 1A Boost Converter Utilizing the LTC3402

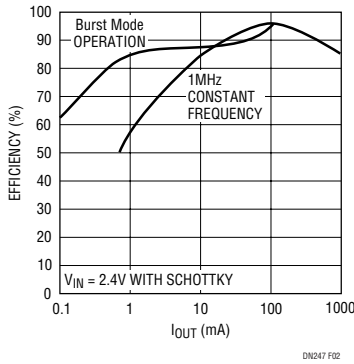

Figure 2. Efficiency of the Circuit in Figure 1

at the V_C pin with respect to the inductor current is typically 170mA/100mV, so the amount of signal injected is proportional to the anticipated change of inductor current with load. The outer voltage loop performs the remainder of the correction, but because of the load feedforward signal, the range over which it must slew is greatly reduced. This results in an improved transient response. The load transient response of the circuit in Figure 1 for a 100mA to 1A load step is shown in Figure 3. A logic-level feedforward signal is coupled through components C5 and R6. The peak-to-peak output voltage ripple for just 66 μ F of output capacitance is 330mV. To

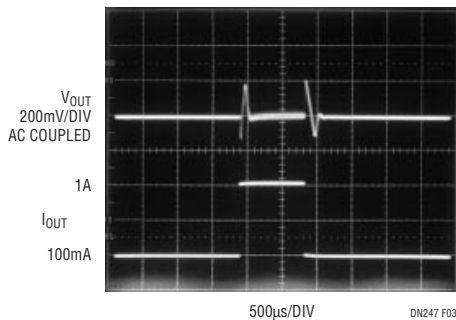
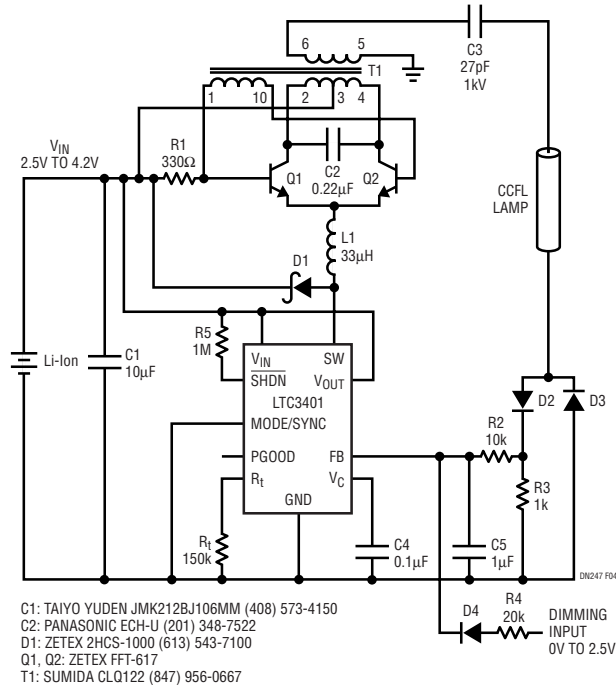

Figure 3. Transient Response of DC/DC Converter with 100mA to 1A Load Step

achieve this ripple without the load feedforward signal, the output capacitance would have to increase to over 150 μ F.

High Efficiency Li-Ion CCFL Backlight Application

Small portable applications with CCFL backlights, such as PDAs, require a highly efficient backlight converter solution to maximize operating time before recharging. A high efficiency Li-Ion CCFL supply is shown in Figure 4. The LTC3401 is set up as a current regulator rather than a voltage regulator and provides the tail current to the self-oscillating resonant Royer circuit that generates the high voltage sinusoidal wave to the lamp. The lamp dimming is provided by means of a control voltage, but alternate dimming techniques can be used.



- C1: TAIYO YUDEN JMK212BJ106MM (408) 573-4150
- C2: PANASONIC ECH-U (201) 348-7522
- D1: ZETEX ZHGS-1000 (613) 543-7100
- Q1, Q2: ZETEX FFT-617
- T1: SUMIDA CLQ122 (847) 956-0667

Figure 4. High Efficiency, Compact CCFL Supply with Remote Dimming

Data Sheet Download

<http://www.linear-tech.com/go/dnLTC3401>
<http://www.linear-tech.com/go/dnLTC3202>

For literature on our DC/DC Converters, call **1-800-4-LINEAR**. For applications help, call (408) 432-1900, Ext. 2377